

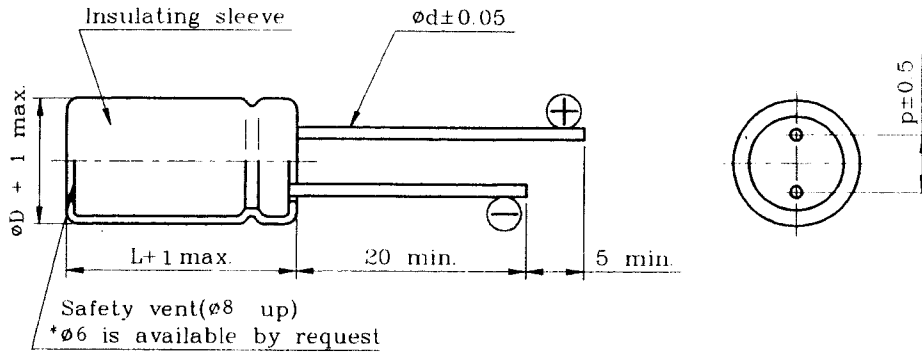

**EHR SERIES**

**Diagram of dimensions**



Dφ	5	6	8	10	13	16	18
F	2.0	2.5	3.5	5	5	7.5	7.5
dφ	0.5		0.6			0.8	

**Case Size of Standard Products**

UF \ WV	6.3	10	16	25	35	50	63	100
0.1 - 0.47					→	5x11	5x11	5x11
1	ALL BLANK VOLTAGE ON SLEEVE MARKING				→	5x11	5x11	5x11
2.2	IS SAME VOLTAGE “→” POINT TO				→	5x11	5x11	5x11
3.3					→	5x11	5x11	5x11
4.7					→	5x11	5x11	5x11
10		→	5x11	5x11	5x11	5x11	5x11	6.3x11
22		→	5x11	5x11	5x11	5x11	6.3x11	8x12
33		→	5x11	5x11	5x11	6.3x11	6.3x11	10x13
47	→	5x11	5x11	5x11	6.3x11	6.3x11	8x12	10x16
100	5x11	5x11	5x11/6.3x11	6.3x11	8x12	8x12	10x13	13x21
220	6.3x11	6.3x11	6.3x11/8x12	8x12	10x13	10x16	10x21	16x26
330	6.3x11	8x12	8x12	10x13	10x16	10x21	13x21	16x32
470	8x12	8x12	8x12/10x13	10x16	10x21	13x21	13x26	16x32
1000	10x13	10x13	10x21	13x21	13x26	16x26	16x32	
2200	10x21	13x21	13x21	16x26	16x32	18x36	18x40	
3300	13x21	13x26	16x26	16x32	18x36	18x40		
4700	13x26	16x26	16x32	16x36	18x40			
6800	16x26	16x32	18x36	18x40				
10000	16x32	18x36	18x40					

UF \ WV	160	200	250	350	400	450
0.47	5x11	5x11	5x11	6.3x11	6.3x11	6.3x11
1	6.3x11	6.3x11	6.3x11	6.3x11	8x12	8x12
2.2	6.3x11	6.3x11	8x12	10x13	10x13	10x16
3.3	6.3x11	8x12	8x12	10x13	10x16	10x21
4.7	8x12	8x12	10x13	10x16	10x16	10x21
10	10x13	10x16	10x16	10x21	13x21	13x26
22	10x16	10x21	13x21	13x26	16x26	16x32
33	10x21	13x21	13x21	16x26	16x32	16x36
47	13x26	13x26	13x26	16x32	16x36	18x40
100	16x26	16x26	16x32			
220	16x36					