

MULTILAYER CERAMIC CAPACITORS EPOXY COATED RADIAL TYPE

Application

NPO : Temperature compensation type, have little or no change in capacitance with variation in temperature. Hence, they are used in radio-frequency oscillators, precision timing circuits, ultra stable amplifiers, etc.

X7R : Temperature stable type for by-pass and decoupling in radio and television receivers, computers servo systems. Audio tone, and coupling, etc., where moderate capacitance variations are permissible and dissipation factor is not critical.

Z5U/Y5V : General type for by-pass and filtering applications.

Construction

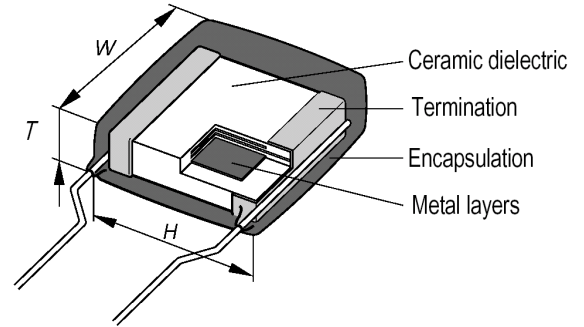

Part Number Designation:

<u>R15</u>	<u>Z</u>	<u>104</u>	<u>M</u>	<u>1H</u>	<u>L</u>	<u>5</u>	<u>L</u>	
SIZE	T.C	Capacitance-Code	Tolerance	Voltage	Lead shape	Lead space	Package-Lead-length	
R15	N=NPO	Two significant digits	A=±0.05PF	F=±1%	1C=16V 1E=25V	L=Straight	2=2.54±0.8	R=Tape/Reel
R20	W=X7R	+NO. of zeros.	B=±0.10PF	G=±2%	1H=50V 1J=63V	Y=Inside	5=5.08±0.8	B=Tape/Box
R25	Z=Z5U	Example	C=±0.25PF	J=±5%	2A=100V 2E=250V	Crimp	(mm)	6=6±1mm
	Y=Y5V	102=1000pf	D=±0.50PF	K=±10%	2H=500V 3A=1KV	H=High seated		L=25.4mm(min)
		223=22000pf	M=±20%		3D=2KV 3F=3KV	A=Slope		
		104=100000pf	Z=+80/-20%					

1. LEAD SHAPE :

R15 L	R20 Y	R25 L
R15 H	R20 H	R15 A

MULTILAYER CERAMIC CAPACITORS EPOXY COATED RADIAL TYPE

2. LEAD SPACE (F)

CODE	LEAD SPACE (mm/inch)	
2	2.54±0.8	0.1±0.032
5	5.08±0.8	0.2±0.032

3. LEAD LENGTH (L)

CODE	LEAD LENGTH	REMARK
6	6mm±1mm	Specified lead length upon request.
L	25.4mm (min)	

4. BODY SIZE & DIMENSION

Size code	Lead style available	Capacitance Range				Dimensions (mm)					
		NPO	X7R	Z5U	Y5V	H max	W max	T max.	d±0.05	F±0.08	P
R15	L	50V: 0.47-4700pF	50V: 220pF-0.1uF	50V: 0.01uF-0.22uF	50V: 0.01-0.33uF	3.8	3.8	2.5	0.5	2.54	---
	H, A	100V: 0.47-2700pF	100V: 220pF-0.1uF		25V: 0.47-1.0uF	3.8	3.8	2.5	0.5	5.08	2.0
R20	Y	25V: 0.12-0.47uF	25V: 1.0-2.2uF	50V: 0.22uF-1.0uF	16V: 10-22uF	5.0	6.0	3.0	0.5	2.54	2.0
	H	50V: 5600pF-0.01uF	50V: 0.1-1.0uF		25V: 2.2-4.7uF	5.0	6.0	3.0	0.5	5.08	2.0
R25	L	25V: 0.1uF	100V: 0.18-0.47uF	100V: 0.47uF-1.5uF	16V: 47uF	6.5	6.5	4.0	0.5	5.08	---
		50V & 100V 0.012-0.022uF			25V: 22uF						
					50V: 10uF						

Typical Performance Characteristics

Specifications

Temperature coefficient

- NPO: ± 30PPM/°C, -55°C to +125°C
- X7R: ± 15%, -55°C to +125°C
- Z5U: +22%, -56%, +10°C to +85°C
- Y5V: +22%, -82%, -30°C to +85°C

Capacitance test 25°C

- NPO: 1 VRMS max at 1 KHz (1 MHz for 100pF or less)
- X7R: 1 VRMS max at 1 KHz
- Z5U: 1 VRMS max at 1 KHz
- Y5V: 1 VRMS max at 1 KHz

Dissipation Factor 25°C

NPO: 0.15% max at 1KHz, 1VRMS max (1 MHz for 1000pF or less)	
Z5U: 5% max (at 1KHz, 1VRMS max)	
X7R: (at 1KHz, 1VRMS max)	Y5V: (at 1KHz, 1VRMS max)
Max Rated voltage	Max Rated voltage
2.5% ≥50V	5% ≥50V
3.5% 25V & 16V	7% 25V & 16V
5.0% 10V & 6.3V	10% 10V & 6.3V

Dielectric strength 25°C (Flash Test)

- NPO and X7R: 300% rated voltage for 5 seconds with 50 mA. max charging current.
- Z5U and Y5V: 250% rated voltage for 5 seconds with 50 mA. max charging current

LifeTest :

(1000 hrs at max temp. applied with Flash test voltage Recovery: 6-24 hrs for NPO and 24± 2 hrs for X7R & Z5U)

- NPO: ≤ ± 3% at 200% rated voltage, 125°C
- X7R: ≤ ± 3% at 200% rated voltage, 125°C
- Z5U: ≤ ± 3% at 200% rated voltage, 85°C
- Y5V: ≤ ± 3% at 200% rated voltage, 85°C

Insulation Resistance after 60 sec., charging at rated voltage, 25°C, 55% R.H. max

- NPO: 100GΩ or 1000MΩ-uF whichever is less
- X7R : 10GΩ or 100MΩ-uF whichever is less
- Z5U : 10GΩ or 100MΩ-uF whichever is less
- Y5V : 10GΩ or 1000MΩ-uF whichever is less

MULTILAYER CERAMIC CAPACITORS EPOXY COATED RADIAL TYPE

TEMPERATURE CHARACTERISTICS SPECIFICATIONS

