



# GBPC15/25/35/50 SERIES

## GLASS PASSIVATED BRIDGE RECTIFIERS

REVERSE VOLTAGE - 50 to 1000Volts  
 RWARD CURRENT - 15/25/35/50Amperes

### FEATURES

- Surge overload -300~450 amperes peak
- Low forward voltage drop
- Mounting position :Any
- Electrically isolated base-2000 Vlots
- Solderable 0.25" FAST ON terminals
- Materials used carries U/L recognition

### GBPC

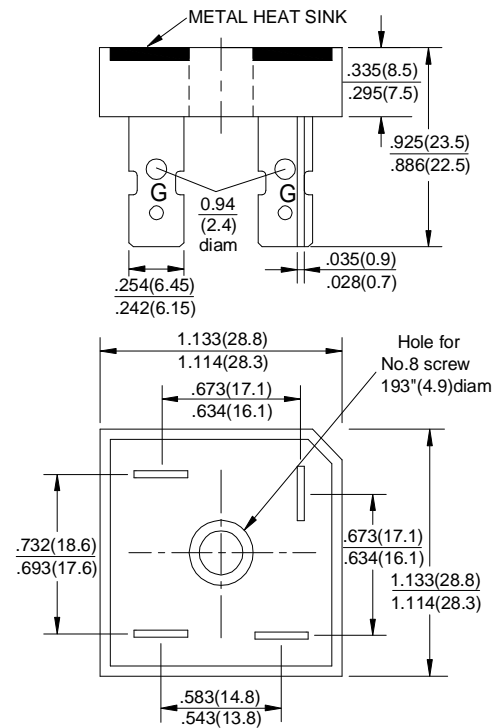

Dimensions in inches and (millimeters)

## MAXIMUM RATINGS AND ELECTRICAL CHARACTERISTICS

Rating at 25°C ambient temperature unless otherwise specified.

Resistive or inductive load 60Hz.

For capacitive load, derate current by 20%

CHARACTERISTICS	SYMBOL	GBPC	GBPC	GBPC	GBPC	GBPC	GBPC	GBPC	UNIT	
		15005	1501	1502	1504	1506	1508	1510		
		25005	2501	2502	2504	2506	2508	2510		
		35005	3501	3502	3504	3506	3508	3510		
		50005	5001	5002	5004	5006	5008	5010		
Maximum Recurrent Peak Reverse Voltage	V <sub>RRM</sub>	50	100	200	400	600	800	1000	V	
Maximum RMS Bridge Input Voltage	V <sub>RMS</sub>	35	70	140	280	420	560	700	V	
Maximum DC Blocking Voltage	V <sub>DC</sub>	50	100	200	400	600	800	1000	V	
Maximum Average Forward Rectified Output Current @ T <sub>c</sub> =55°C	I <sub>(AV)</sub>	GBPC 15	15	GBPC 25	25	GBPC 35	35	GBPC 50	50	A
Peak Forward Surge Current 8.3ms Single Half Sine-Wave Super Imposed on Rated Load	I <sub>FSM</sub>	15	300	25	350	35	400	50	450	A
Maximum Forward Voltage Drop Per Element at 7.5/12.5/17.5/25.0 A Peak	V <sub>F</sub>	1.1							V	
Maximum Reverse Current at Rated DC Blocking Voltage Per Element @ T <sub>J</sub> =25°C	I <sub>R</sub>	10							μA	
Operating Temperature Range	T <sub>J</sub>	-55 to +150							°C	
Storage Temperature Range	T <sub>STG</sub>	-55 to +150							°C	

# RATING AND CHARACTERISTIC CURVES

## GBPC15/25/35/50 SERIES



FIG.1-MAXIMUM FORWARD SURGE CURRENT

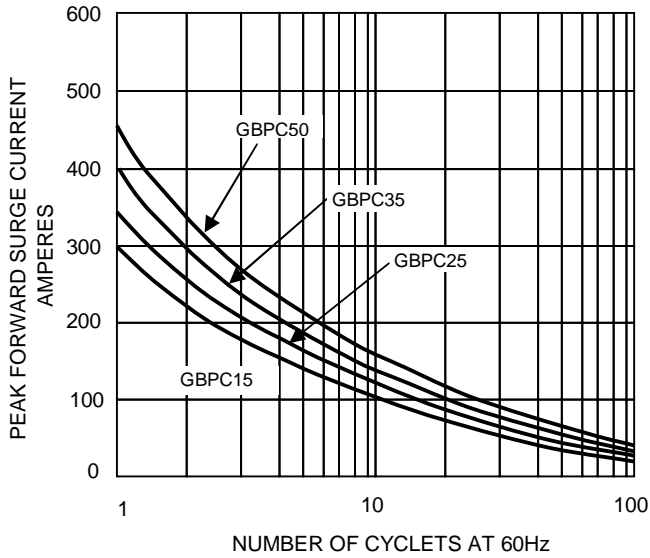

FIG.2- DERATING CURVE OUTPUT RECTIFIED CURRENT

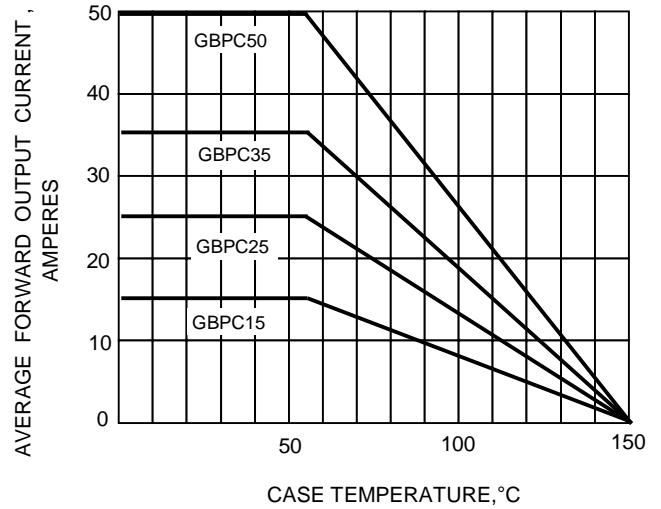

FIG.3-TYPICAL FORWARD CHARACTERISTICS

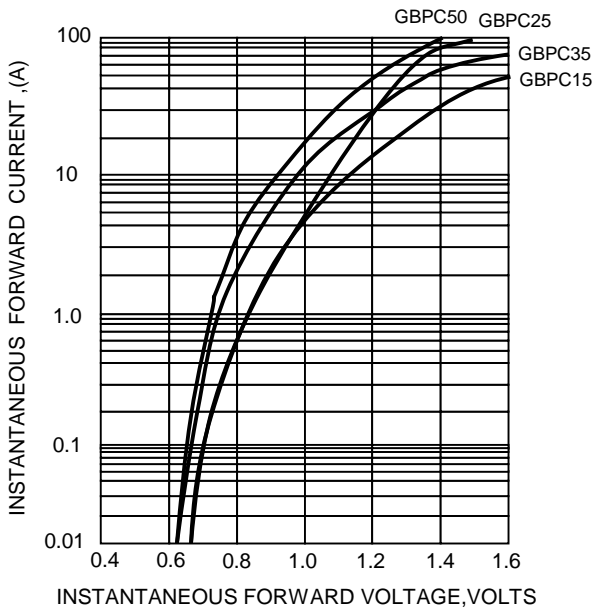

FIG.4-TYPICAL REVERSE CHARACTERISTICS

