

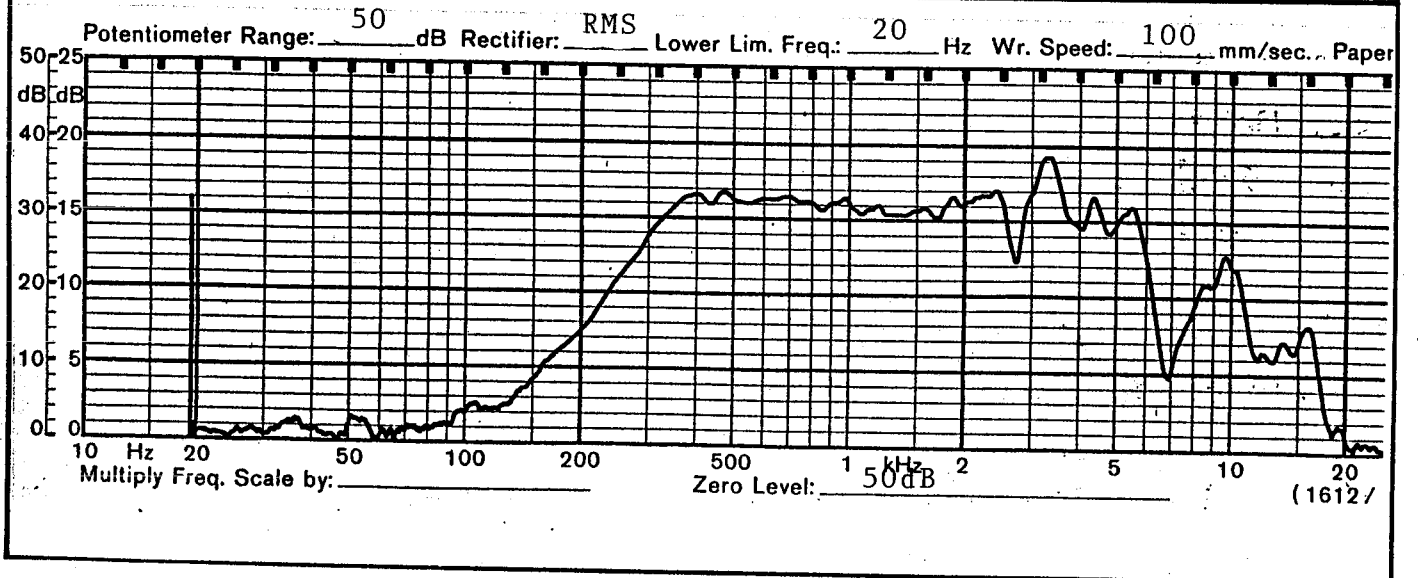

規 格 書 SPEAKER SPECIFICATION

客 戶 Customers Name		承 認	審 核	製 作
名 稱	客戶機種名稱 Customers No.			
Model	本廠機種名稱 Our Model No. GA0401MX (ROHS)			
1	形 式 Type			
2	口 徑 Nominal Size	40 mm.	1-1/2" inch.	
3	公 稱 阻 抗 Impedance	8 Ω ± 15%	at. 800 Hz.	1 v.
4	最低共振週波數 Resonance fo	550 Hz. ± 110 Hz.	F0 Hz.	1 v.
5	出 力 音 壓 S.P. Level	82 dB/w ± 3 dB	0.2 _w 50 cm average at 600, 800, 1K, 1.2K Hz.	
6	出力音壓週波數特性 Response	fo Hz ~ 6.1K Hz MAX 10dB		
7	交 叉 週 波 數 Crossover Freq.	Hz Hz	dB/OCT	Net work
8	許 容 入 力 Input Power	定 格 入 力 Nominal input 0.2 w.	最 大 入 力 Handling Capacity	0.5 w.
9	動 作 Operation	Must be normal at program source 0.2 w.		
10	聲 音 異 常 Buzz, Rattle, etc.	Must be normal at Sine Wave 1.26 v.		
11	磁 束 密 度 Flux Density	Gauss ± 10%		
12	總 磁 束 Total Flux	Max well min		
13	磁 鐵 Magnet	Size 13 x 10 mm	gr	oz
14	重 量 Total weight		gr	oz
15	連 續 負 荷 Lond Test	After test meet item 9 and 10 White noise 0.2 W. 5 Hours		
16	失 真 率 Distortion	以 內 % MAX Hz W.		
17	耐 熱 性 Heat Test	After test meet item 9 and 10 70 ± 2 ± °C 20-50 %R. H 5 Hours		
18	耐 濕 性 Humidity Test	After test meet item 9 and 10. 40 ± 2 ± °C 90-95 % R.H 5 Hours		

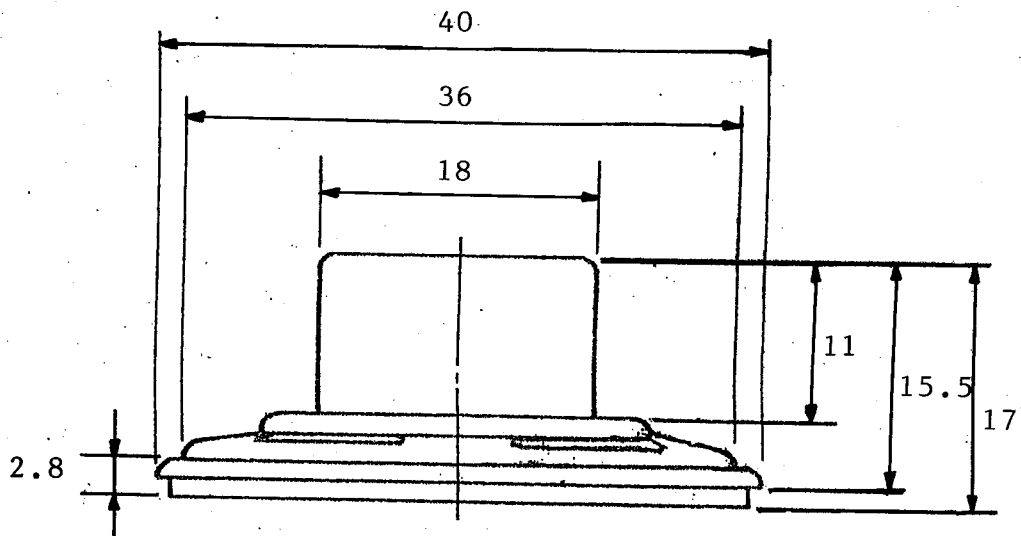

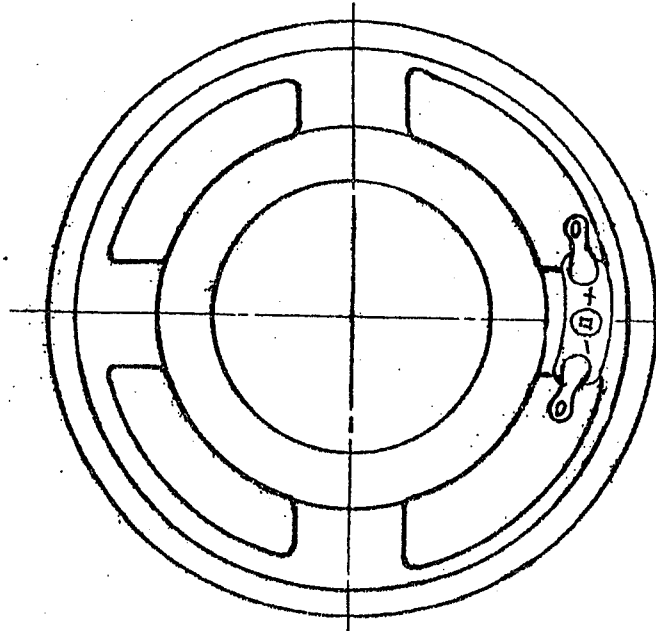

TOLERANCE: ± 0.5 M/M

APPROVED	CHECKED	DRAWING	CUSTOMER'S PART NO.
			AMAOTO'S PART NO. GA0401MX

AMAOTO INDUSTRIAL CO., LTD.