

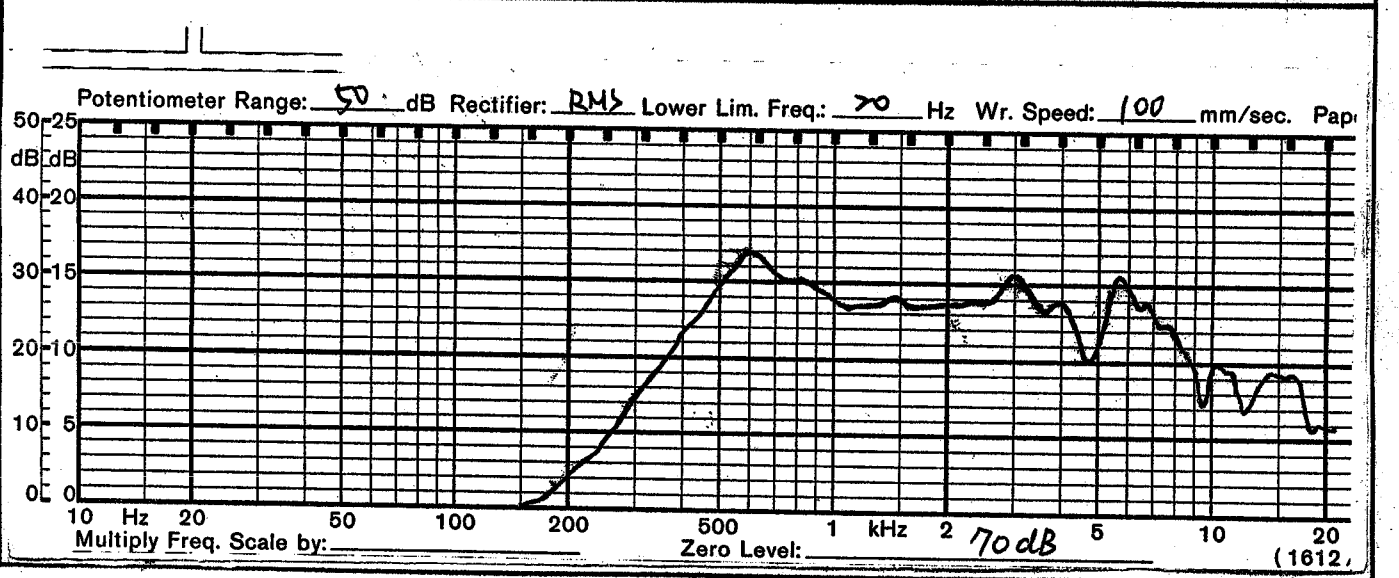

# 規 格 書 SPEAKER SPECIFICATION

客 戶 Customers Name		承 協	審 核	製 作
名 稱	客戶機種名稱 Customers No.			
	本廠機種名稱 Our Model No.      GF0876MX      (ROHS)			
Model				
1	形 式 Type			
2	口 徑 Nominal Size	87 mm.	3-1/4" inch.	
3	公 稱 阻 抗 Impedance	8 Ω ± 15%	at. 800 Hz. 1 V.	
4	最低共振週波數 Resonance fo	580 Hz. ± 116 Hz.	FO Hz. 1 V.	
5	出 力 音 壓 S.P. Level	97 dB/w ± 3 dB	1 w 50 cm average at	
6	出力音壓週波數特性 Response	fo Hz ~ 18K Hz      MAX 10dB	1K, 1.3K, 1.6K, 2K Hz.	
7	交 叉 週 波 數 Crossover Freq.	Hz      Hz	dB/OCT      Net work	
8	許 容 入 力 Input Power	定 格 入 力 Nominal input 12 w.	最 大 入 力 Handling Capacity 15 w.	
9	動 作 Operation	Must be normal at program source 12 w.		
10	聲 音 異 常 Buzz, Rattle, etc.	Must be normal at Sine Wave 9.8 V.		
11	磁 束 密 度 Flux Density	Gauss ± 10%		
12	總 磁 束 Total Flux	Max well min		
13	磁 鐵 Magnet	Size 60 x 32 x 8 mm	gr 2.8	oz
14	重 量 Total weight		gr	oz
15	連 續 負 荷 Lond Test	After test meet item 9 and 10	White noise 12 W.	48 Hours
16	失 真 率 Distortion	以 內 % MAX	Hz	W.
17	耐 熱 性 Heat Test	After test meet item 9 and 10	70±2 ±°C      20-50 %R. H	48 Hours
18	耐 濕 性 Humidity Test	After test meet item 9 and 10.	40±2 ±°C      90-95 % R.H	48 Hours

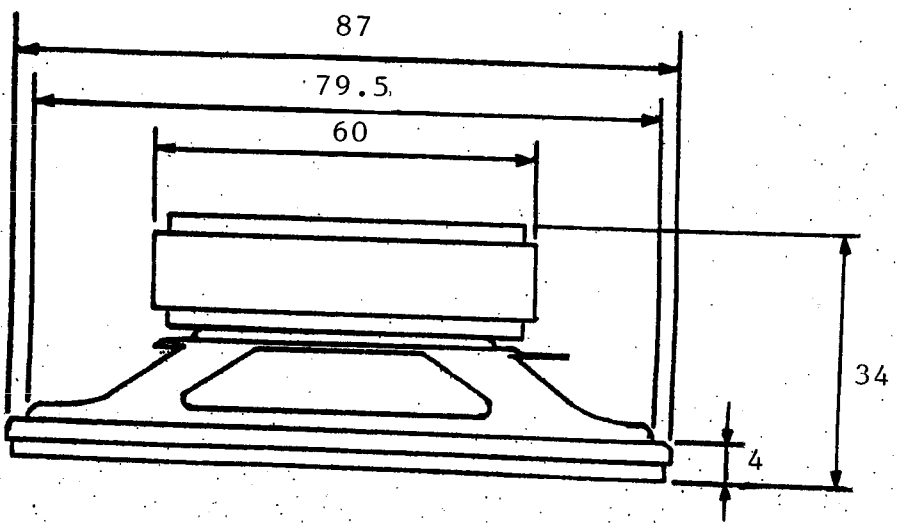

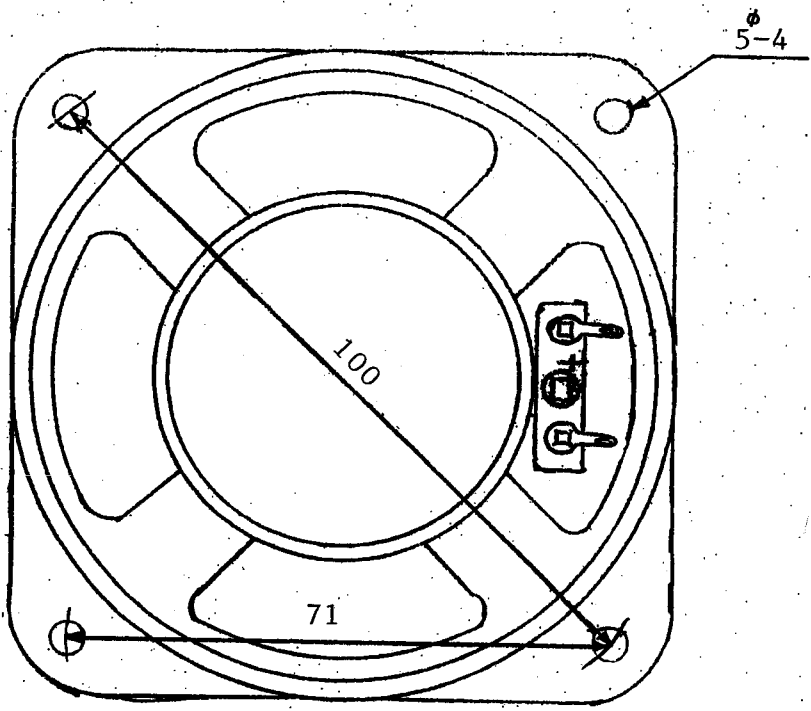

TOERANCE: +/- 0.5 M/M

APPROVED	CHECKED	DRAWING	CUSTOMER'S PART NO.
			AMAOTO'S PART NO. GF0876MX

AMAOTO INDUSTRIAL CO. LTD.