

# SPECIFICATION

## 1. SCOPE

This specification is applied to the piezo-element.

## 2. SPECIFICATION

(at 25°C)

2.1 Resonant Frequency	:	3.0 ± 0.5 KHz
2.2 Resonant Resistance	:	500 Ω max
2.3 Capacitance	:	35000 pF ± 30% at 100Hz
2.4 Input Voltage	:	30 Vp-p max
2.5 Operating Temperature	:	-20~+50°C
2.6 Storage Temperature	:	-20~+70°C
3. DIMENSION	:	as per figure

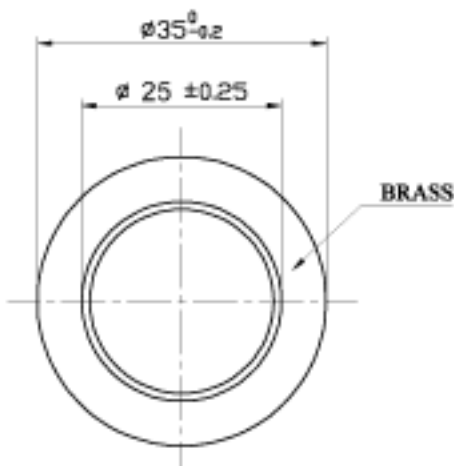

With 100mm UL 1007 28# □  
Red/Black wire

TOLERANCES UNLESS NOTED OTHERWISE

.X ±  
.XX ±  
.XXX ±

90° FORMED +2°  
ANGLES -1°

FIRST ANGLE PROJECTION



DRAWN	
DESIGN	
CHECKED	
APPROVED	
DATE	03.08.07
CONTRACT NO.	
AGENCY APPROVAL	

Part Number

FT-35T-3.0A1

DWG NO.

CUSTOMER

JPR ELECTRONICS

CUSTOMER NO.

VER	1.1	SCALE	
UNIT	mm	SHEET	

1

2

3

4