

SPECIFICATION

1. SCOPE

This specification is applied to the piezo-element.

2. SPECIFICATION (at 25 °C)

- 2.1 Resonant Frequency : 2.6 ± 0.5 KHz
- 2.2 Resonant Resistace : 250 Ω max
- 2.3 Capacitance : 28000 pF ± 30% at 100Hz
- 2.4 Input Voltage : 30 Vp-p max
- 2.5 Operating Temperature : -20 ~ +50 °C
- 2.6 Storage Temperature : -20 ~ +60 °C

3. DIMENSION as per figure

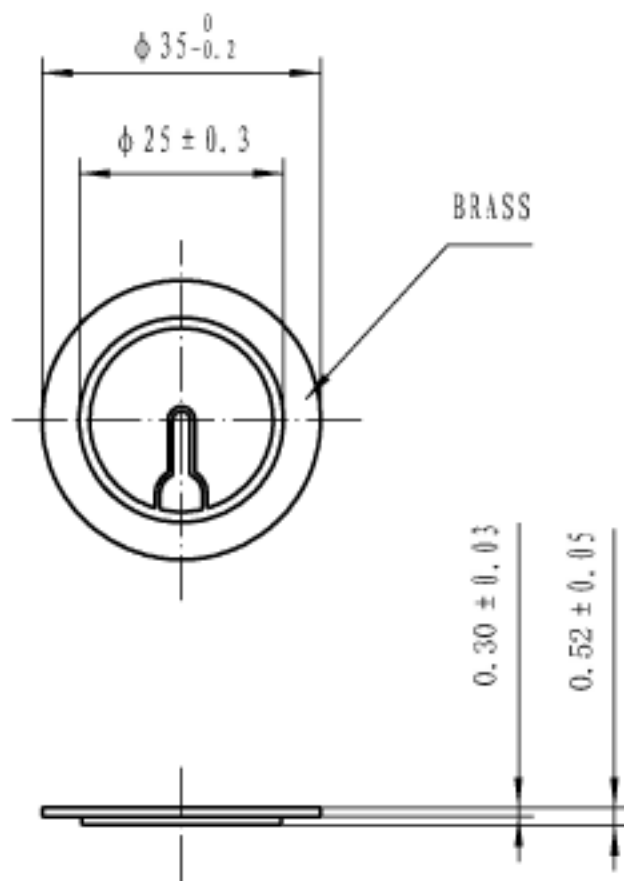

| | | | | | | | | |
|--|-------|------|----------|-----------------|-----------------|-------|-------|--|
| TOLERANCES UNLESS NOTED OTHERWISE .X ± .XX ± .XXX ± 90° FORMED +2° ANGLES -1° | | SIGN | DATE | Part number | CUSTOMER | | | |
| | PREP. | | 01.09.20 | FT-35T-2.6B1 | JPR ELECTRONICS | | | |
| | ENG. | | | | CUSTOMER NO. | | | |
| | QA. | | | DWG NO. | | | | |
| | PROJ. | | | | REV | 1.1 | SHEET | |
| CONTRACT NO. | | | | UNIT: | mm | SCALE | | |
| FIRST ANGLE PROJECTION | | | | AGENCY APPROVAL | | | | |
| | | | | | | | | |