

SPECIFICATION:

- (1) ITEM NO.: CH 25-2032
- (2) MATERIALS:
HOUSING-PBT 30%GF UL94V-0
CONTACT-PHOSPHOR BRONZE,
T=0.6 mm
PLATING TIN 100u" , NI 80u"
- (3) BATTERY HOLDER,
ROUND TYPE.
DIA. D= 19.8 mm , T= 3.2 mm
NICKLE PLATED, BLACK COLOR
INSULATOR : PBT

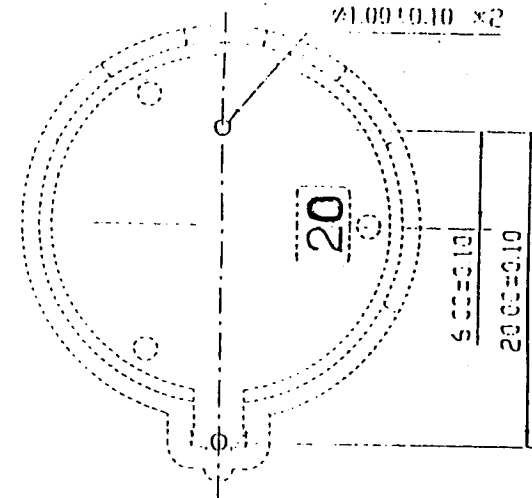

RECOMMEND PCB LAYOUT
COMPONENT SIDE

3			COMFORTABLE ELECTRONIC CO.LTD.		
2			NAME BATTERY HOLDER CH 25-2032		
1			SCALE	APPD.	<i>Wang Jia</i>
NO.	MODIFICATION	DATE	UNIT	CHKD.	<i>Wang Jia</i>
			MAT'L	DWN.	LING
			DATE	DR NO.	

