

**LIGHT ACTIVATE ALARM**  
**CODE 245** **LEVEL 1**

This circuit will sound an alarm when exposed to an adjustable amount of light.

**Technical specifications:**

- power supply: 12VDC.
- consumption: 22mA max.
- dimensions: 2.38 x 1.24 inches

**How to works:**

The photo-transistor senses how much light is falling on the circuit, when in a lit condition, the voltage is fed to base of TR1 and when in the dark, it has no voltage at the base of TR1. Therefore in the dark TR1 and TR2 aren't on, which means the frequency generation transistors TR3 and TR4 aren't active. In the light TR1 and TR2 turn on causing TR3 and TR4 to oscillate which is then transmitted through a loud-speaker.

**PCB assembly:**

Shown in Figure 3 is the assembled PCB. Starting with the lowest height components first, taking care not to short any tracks or touch the edge connector with solder. Some tracks run under components, and care should be taken not to short out these tracks. If the pins will not enter the holes with ease, use a small drill to slightly enlarge the opening. All components with axial leads should be carefully bent to fit the position on the PCB and then soldered into place. Make sure that the electrolytic capacitors are inserted the correct way around. Some components are particularly sensitive to heat (ie: Transistors, IC's, diodes etc.) extra care must be taken to only apply the iron for as little time as possible, using a pair of pliers to grip the leads will help

conduct heat away. Trim components leads with wire cutters to prevent excess lengths causing a short circuit. Now check that you really did mount them all the right way round!

**Testing:**

Apply power supply 9 volts to the circuit, covering the photo-transistor should stop the alarm, if it does not then adjust VR1 until the circuit functions.

**Figure 1. Installing the components**

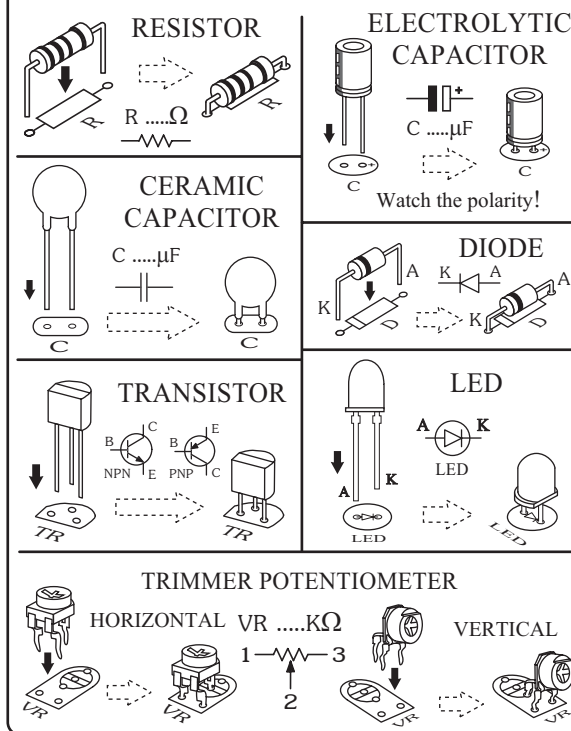

**Troubleshooting:**

The most problem like the fault soldering. Check all the soldering joint suspicious. If you discover the short track or the short soldering joint, re-solder at that point and check other the soldering joint. Check the position of all component on the PCB. See that there are no components missing or inserted in the wrong places. Make sure that all the polarised components have been soldered the right way round.

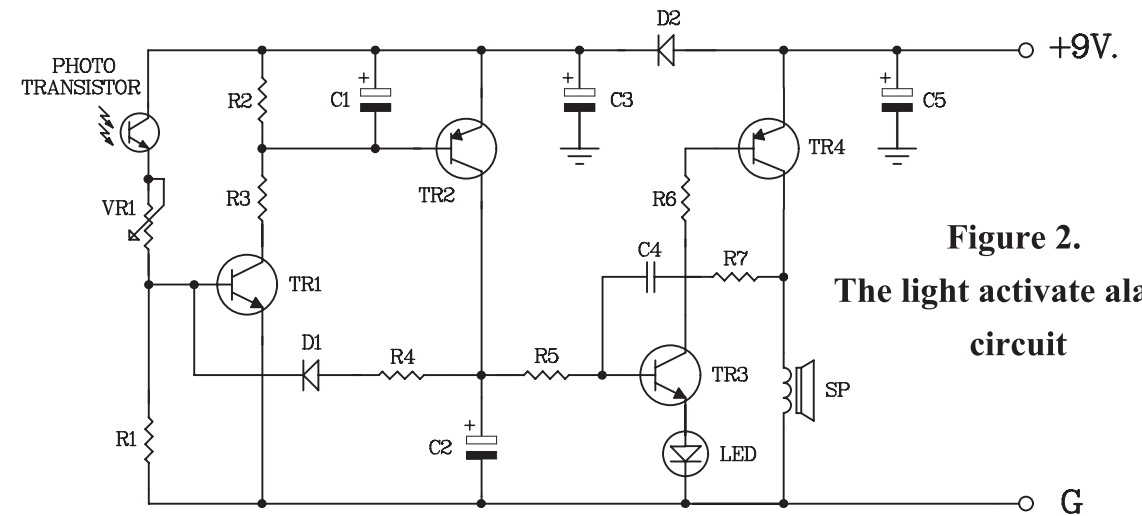

**Figure 2.**  
**The light activate alarm circuit**

**Figure 3. Connections**

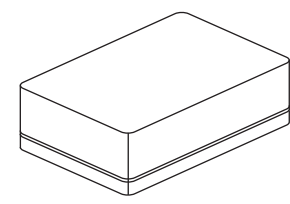
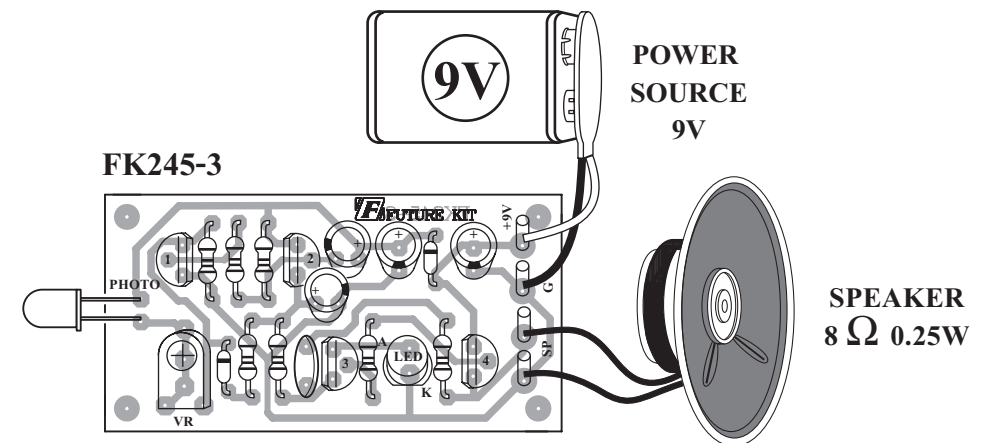

**NOTE:**

**FUTURE BOX FB03 is suitable for this kit.**

**NEW KIT SET**

CODE FK	DESCRIPTION	POWER
277	LOVELY MESSAGE VOICE	3VDC
327	DUAL STATION INTERCOM (TRANSISTOR)	4.5-6VDC
511	TWO FUNCTION INFRARED SENSOR	12VDC
512	DING/DONG DOOR CHIME (PIR SENSOR)	4.5VDC
935	BODY TEMPERATURE	9VDC
936	FOUR DIGITAL COUNTER (PRESETTABLE)	6-12VDC