

**LED FLASHER 10 DOT**  
**CODE 112**

**LEVEL 1**

This LED flasher 10 dot circuit is a basic circuit that is suitable for those who are interested in electronics. Easy application with low price. This circuit has 10 LEDs flash alternately one by one.

**Technical specifications:**

- power supply: 9-12VDC.
- consumption: 14-20mA max.
- adjustable speed with potentiometer.
- PCB dimensions : 2.09 x 2.02 inch.

**How to work:**

Multi-vibrator (TR1 and TR2) is configured as frequency generator. TR1 and TR2 will alternately one by one. If TR1 works, LED1 to LED5 will light on and LED6 to LED10 will light off. But if TR2 works, LED1 to LED5 will light off and LED6 to LED10 will light on. Speed of LED blinking is depending on VR1, R1, R2, C1 and C2. VR1 is used to adjust the speed of LED blinking. R3 to R6 are voltage drop for each LED.

**PCB assembly:**

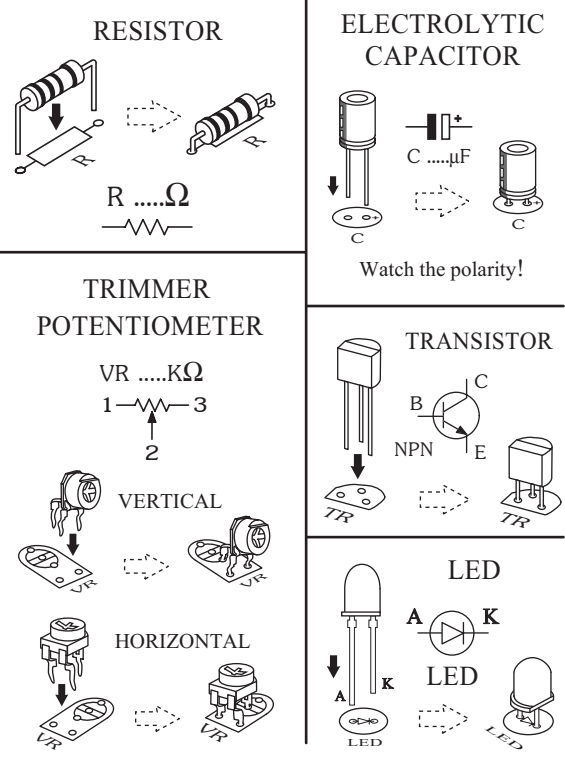
Shown in Figure 3 is the assembled PCB. Starting with the lowest height components first, taking care not to short any tracks or touch the edge connector with solder. Some tracks run under components, and care should be taken not to short out these tracks. All components with axial leads should be carefully bent to fit the position on the PCB and then soldered into place. Make sure that the electrolytic capacitors are inserted the correct way around. The LED has a flat spot on the body which lines up with the line on the overlay. Now check that you really did mount them all the right way round!

**Testing:**

Connect the power supply 9 to 12V to circuit.

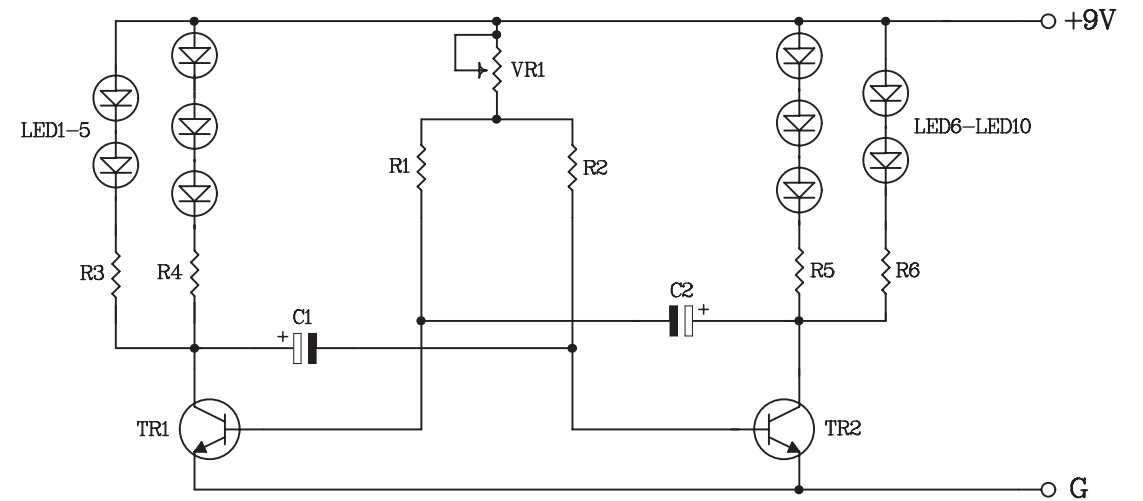
With the positive pole is connected to "+" point and the negative pole is connected to "-" point. All LEDs will display alternately. Adjusting variable resistance 10K, All LEDs will display according to adjusted speed.

**Figure 1. Installing the components**

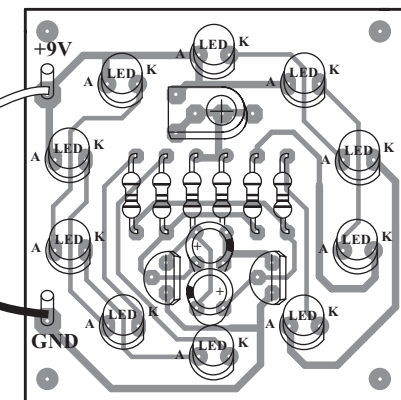


**Troubleshooting:**

The most problem like the fault soldering. Check all the soldering joint suspicious. If you discover the short track or the short soldering joint, re-solder at that point and check other the soldering joint. Check the position of all component on the PCB. See that there are no components missing or inserted in the wrong places. Make sure that all the polarised components have been soldered the right way round.

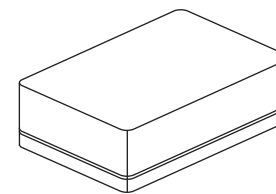


**Figure 2. LED FLASHER 10 DOT circuit**



**FK112-1**

**Figure 3. Connections**



**NOTE:**

**FUTURE BOX FB03 is suitable for this kit.**

NEW KIT SET

CODE FK	DESCRIPTION	POWER
271	LIGHT ACTIVATE ALARM (COCK VOICE) WITH SPEAKER	3VDC
272	SPACE GUN 3 TONE WITH SPEAKER	9VDC