

INTRUDER ALARM (DELAY FUNCTION)
CODE 501 LEVEL 1

Intruder alarm circuit is using photo-transistor to detect light level and having timer and alarm.

Technical specifications:

- power supply : 9VDC.
- consumption : 40mA.(working)
- delay on : approximate 30 to 50 seconds.
- PCB dimensions : 2.80 x 1.55 inches.

How to works:

When first switching on, C8 will be charged voltage through R6. Photo-transistor detects light changing by having TR1, TR2 amplify the signal and transfer to pin13 of IC1/1. During this period, IC1/1 has no response even pin13 is tricked. C1 has to be charged for 30 seconds. After that, if photo-transistor can detect light changing, it will send signal to TR1 and TR2 to pin13 to trick IC1/1, IC1/2 working. Pin3 of IC1/2 will have high voltage, which sent through pin3 of IC1/3 to control IC1/3 oscillate and generate frequency to R12 to TR3. So there is a sound at speaker. C9 will discharge voltage to R7 within 30 seconds, IC1/4 will decrease voltage to pin4 to IC1/2. So pin3 and pin9 of IC1 have no voltage and frequency generator will stop working as well as speaker. If photo-transistor detects light changing again, the circuit will run as above.

PCB assembly:

Shown in Figure 3 is the assembled PCB. Starting with the lowest height components first, taking care not to short any tracks or touch the edge connector with solder. Some tracks run under components, and care should be taken not to short out these tracks. If the pins will not enter the holes with ease, use a small drill to slightly enlarge the opening. All components with axial leads should be carefully bent to fit the position on the PCB and then soldered into place. Make sure that the electrolytic capacitors are inserted the correct way around. Some components are particularly sensitive to heat (ie: Transistors, IC's, diodes etc.) extra care must be taken to only apply the iron for as little time as possible, using a pair of pliers to grip the leads will help conduct heat away. Trim components leads with wire cutters to prevent excess lengths causing a short circuit. Now check that you really did mount them all the right way round!

Testing:
Giving supply to the circuit. Blocking photo-transistor by hand. Waiting for 30-50 seconds and blocking photo-transistor again, there will be a sound at speaker for 30-50 seconds. When blocking again, circuit will alarming and automatically stopping. Variable resistance is used for adjusting detective speed.

Application:
Following instruction according to the figure 3, considering light direction as well or covering with black pipe for better detection. If requires longer alarm period, increase the value of C9.

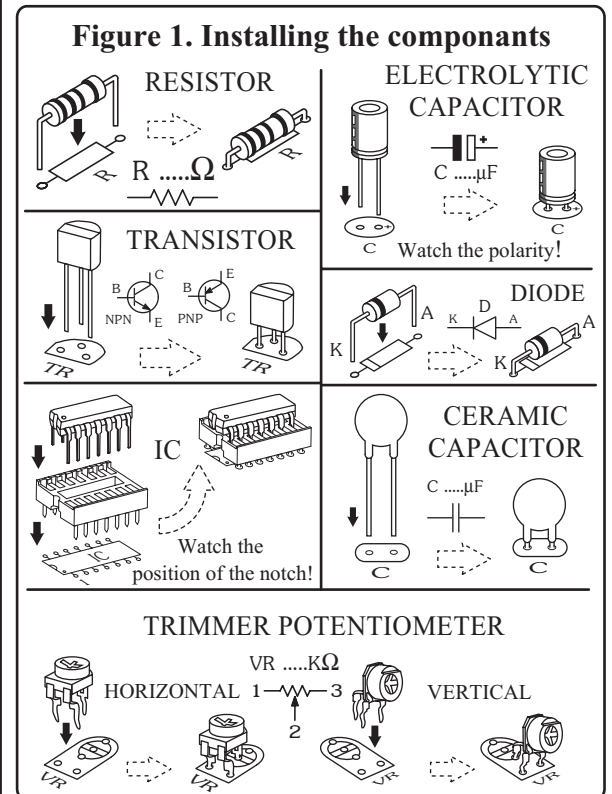

Troubleshooting:
The most problem like the fault soldering. Check all the soldering joint suspicious. If you discover the short track or the short soldering joint, re-solder at that point and check other the soldering joint. Check the position of all component on the PCB. See that there are no components missing or inserted in the wrong places. Make sure that all the polarised components have been soldered the right way round.

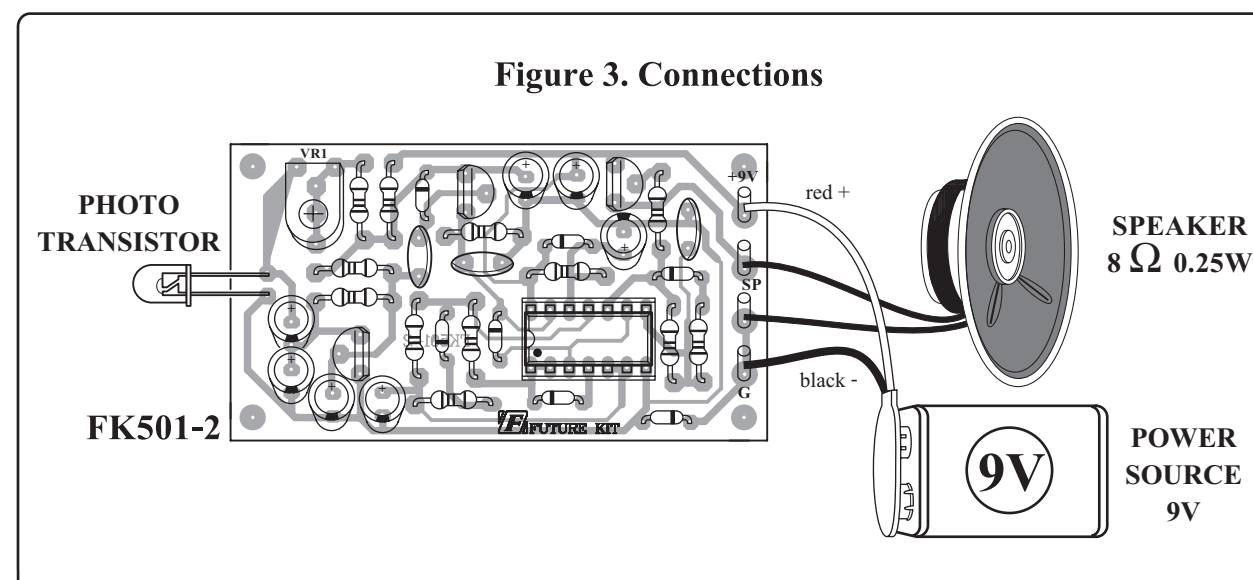
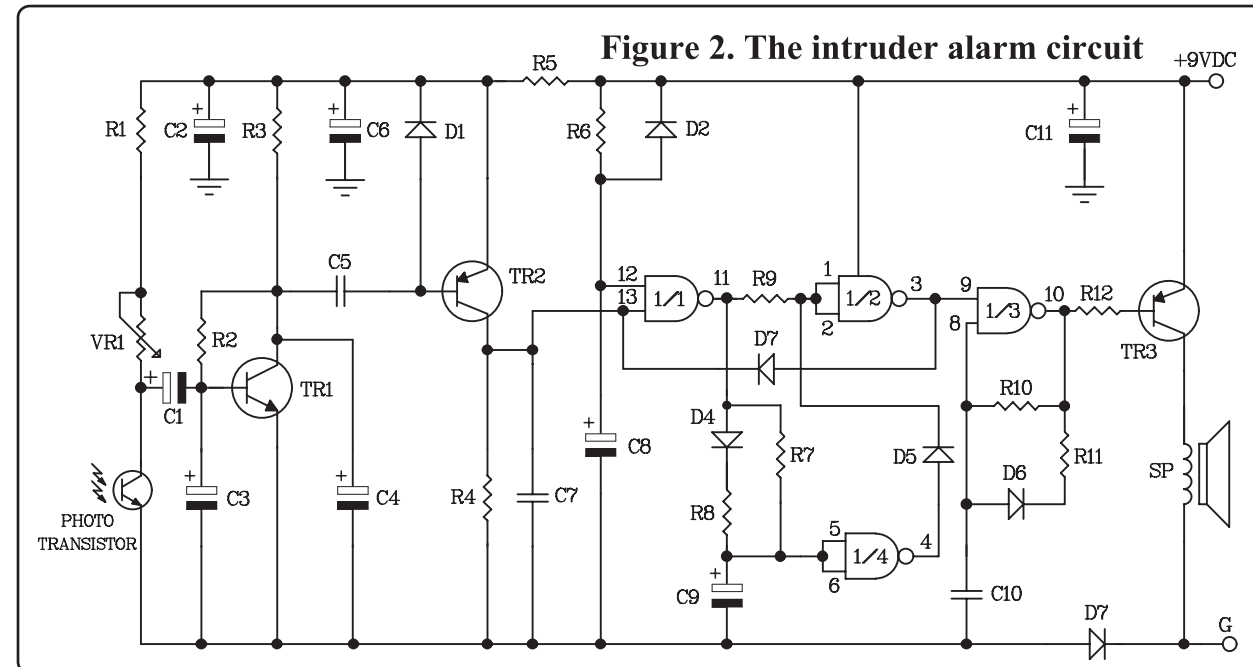

NOTE:
FUTURE BOX FB03 is suitable for this kit.

NEW KIT SET

CODE FK	DESCRIPTION	POWER
170	DANGER FLASHER 42 LED	9-12VDC.
171	TWO LAMP FLASHER	3VDC.
172	THREE STEP FLASHER 19 LED	9-12VDC.
173	HALLOWEEN PUMPKIN FLASHER 23 LED	9-12VDC.
174	ANIMATED LED SIGNBOARD (5x7 DOT MATRIX)	3-5VDC.
327	DUAL STATION INTERCOM (TRANSISTOR)	4.5-6VDC.
512	DING/DONG DOOR CHIME (PIR SENSOR)	4.5-6VDC.
816	VARIABLE REGULATOR 0-50V. 3A.	50VDC.
817	TRANSFORMERLESS POWER SUPPLY 6-9-12V 50mA	220-240VAC.