

SYMBOL	REVISION	APPROVAL	DATE

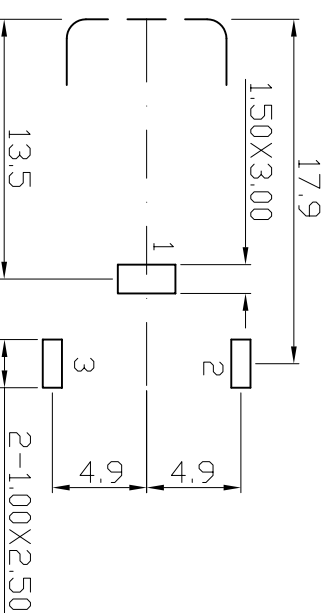

P.C.B. LAYOUT  
(BOTTOM VIEW)

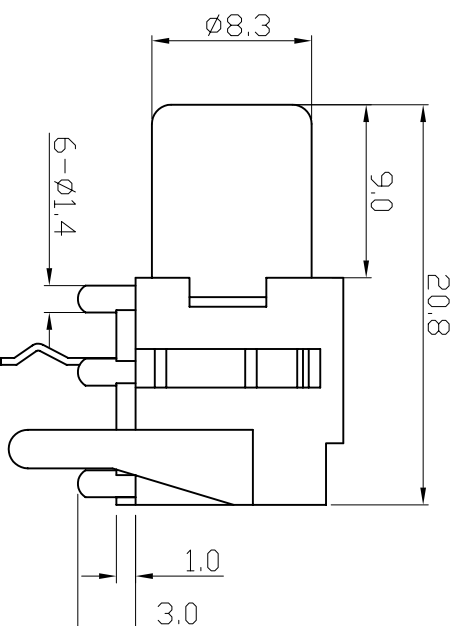
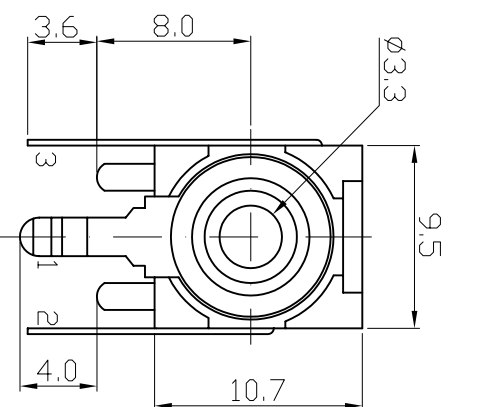
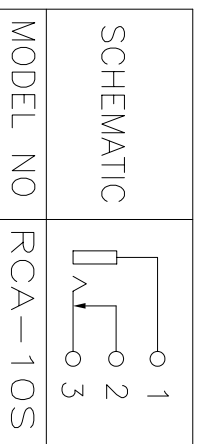

**ROHS COMPLIANT**  
EU Directive 2002/95/EC

ITEM	NAME	MATERIAL	FINISH	SUM
4	Housing	PBT	Black	1
3	Terminal No 3	Phosphor Bronze	Matte Tin Plated	1
2	Terminal No 2	Brass	Matte Tin Plated	1
1	Terminal No 1	Brass	Nickel Plated	1

**SAMLUNG INDUSTRIAL LTD.**

TOLERANCES	X. ± 0.5	Model Name:	RCA JACK
X.X ± 0.3	X.XX ± 0.15	Model No.:	RCA-10S-000-96
ANGLE: ±3°		FILE: Samlung/RCA/RCA-10/PRODUCT/RCA-10S-000-96	
UNIT MM		SCALE: Full	DATE: 2010-10-21
REVISION: A	DWG NO: 2010-PD-10212	DESIGN: /	CHECK: /
		DRAWN: SD.Wu	CHECK: SM.Lin
			APPROVE: SW.Wu

---

## **Product Specification**

Title : RCA JACK  
Item Number : RCA-10N-000-96

**RoHS COMPLIANT**  
EU Directive 2002/95/EC

### **1.General**

#### 1.1 Scope

This specification covers the general requirements of the RCA Jack, applied on audio systems and other related electronic apparatus. Especially this specification applied on the normal plastic for the through hole soldering process.

#### 1.2 Mated Plug

The mated plug should comply with standard plug as shown in the drawing attached.

### **2.Mechanical**

#### 2.1. Terminal Strength

The terminals shall be capable of withstanding a force of 500 grams applied in any direction for 10 seconds without losing or breakdown, except bending the terminals.

#### 2.2. Insertion and Extraction Force

Insertion Force:

Conditions	Value of Specification
Initial Condition	0.5 Kgs To 3.0 Kgs
After Life Test After Humidity Test After Heat Test After Cold Test After Resistance To Soldering Heat Test	0.4 Kgs To 3.0 Kgs

Extraction Force :

Conditions	Value of Specification.
Initial Condition	0.5 Kgs To 3.0 Kgs
After Life Test After Humidity Test After Heat Test After Cold Test After Resistance To Soldering Heat Test	0.4 Kgs To 3.0 Kgs

### 3. Electrical

#### 3.1. Withstand Voltage Test

500 Volts AC/RMS of commercial frequency 50 to 60 Hz applied between adjacent open terminals for 1 minute without breakdown.

#### 3.2. Insulation Resistance

The insulation resistance between mutual insulated contacts should be complied with following specification under 500 Volts DC.

Conditions	Value of Specification
Initial Condition After Life Test After Heat Test After Cold Test After Resistance To Soldering Heat Test	100 M $\Omega$ Min.
After Humidity Test	50 M $\Omega$ Min.
Note : The mate plug used to this measurement shall be allowed to clean and remove oxidation film on the surface before test.	

#### 3.3. Contact Resistance

Contact resistance of jack shall not exceed the value defined in the table listed at a current less than 1.0 Amp. DC by four terminals method

Conditions	Value of Specification.	
	Plug To Contacts	Plug To Ground
Initial Condition After Life Test After Humidity Test After Heat Test After Cold Test After Resistance To Soldering Heat Test	50 m $\Omega$ Max.	30 m $\Omega$ Max.
After Durability Test	100 m $\Omega$ Max.	60 m $\Omega$ Max.
Note : The mate plug used to this measurement shall be allowed to clean and remove oxidation film on the surface before test.		

### 4. Endurance

#### 4.1 Durability Test

The durability test shall consist of 5000 mating cycles of insertion and extraction with the mated plug or the gauge plug at a rate 10~20 cycles per minute, no load condition, with or without lubricant which should be specified the detail requirement. The performance of the jack before and after this test should comply with paragraphs 2b and 3c.

#### 4.2 Measuring Condition

All measurements and test shall be made at a temperature 10°C to 35°C with a relative humidity of 45%RH to 85%RH under standard atmospheric pressure unless otherwise specified conditions.

## **5.Environment**

### **5.1. Humidity Test**

The jack shall be placed in the testing chamber at the condition of  $40^{\circ}\text{C} \pm 2^{\circ}\text{C}$  and the relative humidity of 90% to 95%RH for 96 Hrs, the dew drops on the surface of jack shall be blown off and removed from the surface of jack and then placed in ambient temperature for more than 30 minutes recovery period. The relative test before and after this test should complied with paragraph 3.2.

### **5.2 Heat Test**

The jack shall be placed in the testing chamber at a temperature of  $70^{\circ}\text{C} \pm 2^{\circ}\text{C}$  and the relative humidity of less than 50%RH for 96 Hrs and then placed in ambient temperature for more than 30 minutes recovery period. The relative test before and after this test should complied with paragraph 3.2.

### **5.3 Cold Test**

The jack shall be placed in the testing chamber at a temperature of  $-40^{\circ}\text{C} \pm 2^{\circ}\text{C}$  and the relative humidity of less than 50%RH for 96 Hrs and then placed in ambient temperature for more than 30 minutes recovery period. The relative test before and after this test should complied with paragraph 3.2.

## **6.Soldering Test**

### **6.1. Solder ability**

The terminal of jack tested shall be dipped into soldering flux or equivalent for a period of 5 to 10 seconds and then immersed into molten solder, Sn63, at a controlled temperature of  $235^{\circ}\text{C} \pm 5^{\circ}\text{C}$  for  $3 \pm 0.5$  seconds after aging.

### **6.2. Resistance to Soldering Heat**

The terminals should be immersed into molten solder, Sn63, at a controlled temperature of  $230^{\circ}\text{C} \pm 5^{\circ}\text{C} < 5$  seconds. The relative test before and after this test should complied with paragraph 2b and 3. The outlook of the jack should have no remarkable deterioration.

## **7.Operating Temperature**

The range :  $-25$  to  $+ 85^{\circ}\text{C}$

## **8.Rating**

Rated voltage : 12 Volts DC

Rated current : 1 Amperes

## 9. Material and finish

<b>Name</b>	<b>Material</b>	<b>Color &amp; Plating</b>
Housing	PBT	Black
Terminal No. 3	Phosphor Bronze	Matte Tin Plated
Terminal No. 1	Brass	Nickel Plated

----- **End** -----