

SCHEMATIC

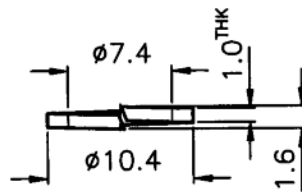

SPRING WASHER

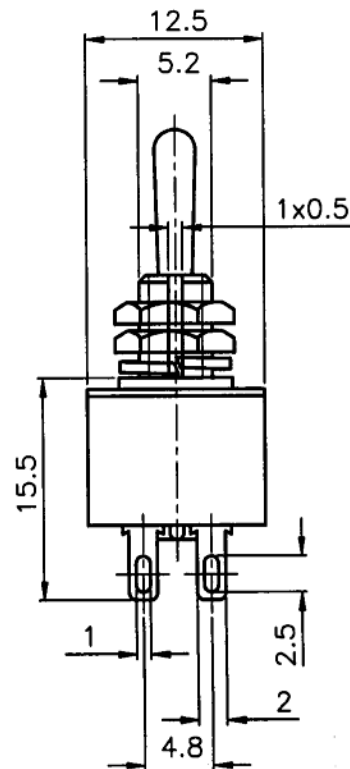
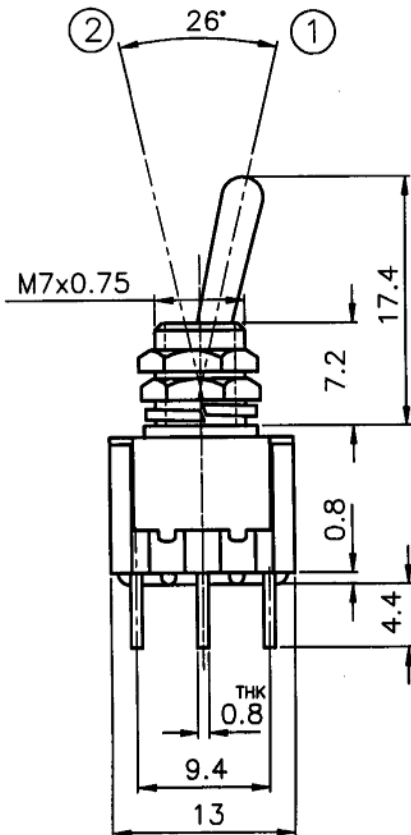
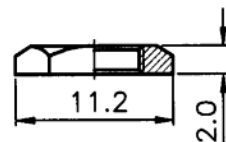

M7X0.75 NUT

ISSUED	SPECIFICATION (INITIAL)	TITLE: TOGGLE SWITCH 2P2T		
	RATING: AC 125V 3A	MODEL NO: WT-22102-T(P1)17.4-S-#353		
	CONTACT RESISTANCE: Not more than 30mΩ	UNIT: m m	DWN	LIU 07.08.07
	INSULATION RESISTANCE: 100MΩ AT 500V DC	SCALE: 2 : 1	CHK'D	<i>LIU</i> 7/8-07
	WITHSTAND VOLTAGE: AC 1000V FOR 1 MIN	TOLERANCE: ±0.2	APPD.	<i>LIU</i> 7/8-07
	OPERATION FORCE: 300 ± 150g	DRAWING NO. A70414-00		
	SWITCHING LIFE: 10000 Cycles (6-10c/m loading)	PROMOTIVE INDUSTRIAL CO., LTD. HONG KONG		
BY:				
DATE:				