

SCHEMATIC

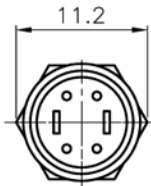
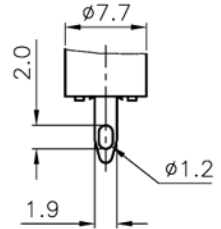
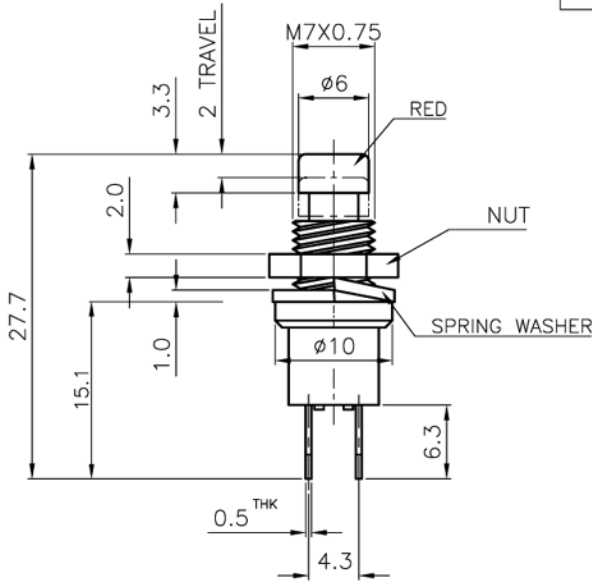

ISSUED	SPECIFICATION (INITIAL)	TITLE: PUSH BUTTON SWITCH (PUSH ON)			
	RATING: DC 50V 0.5A	MODEL NO: PB-11D02-T(H1)R-00-#296			
	CONTACT RESISTANCE: Not more than 30mΩ	UNIT: m m	DWN	YANG	28/02/06
	INSULATION RESISTANCE: 500MΩ at 500V DC	SCALE: 2 : 1	CHK'D		
	WITHSTAND VOLTAGE: AC 500V for 1 min	TOLERANCE: ±0.20	APPD.		
	OPERATION FORCE: 200±150g SWITCHING LIFE: 10000 Cycles (6-10c/m loading)				
BY: DATE:	PROMOTIVE INDUSTRIAL CO., LTD.			DRWG NO: A20285-01	