

R13-29

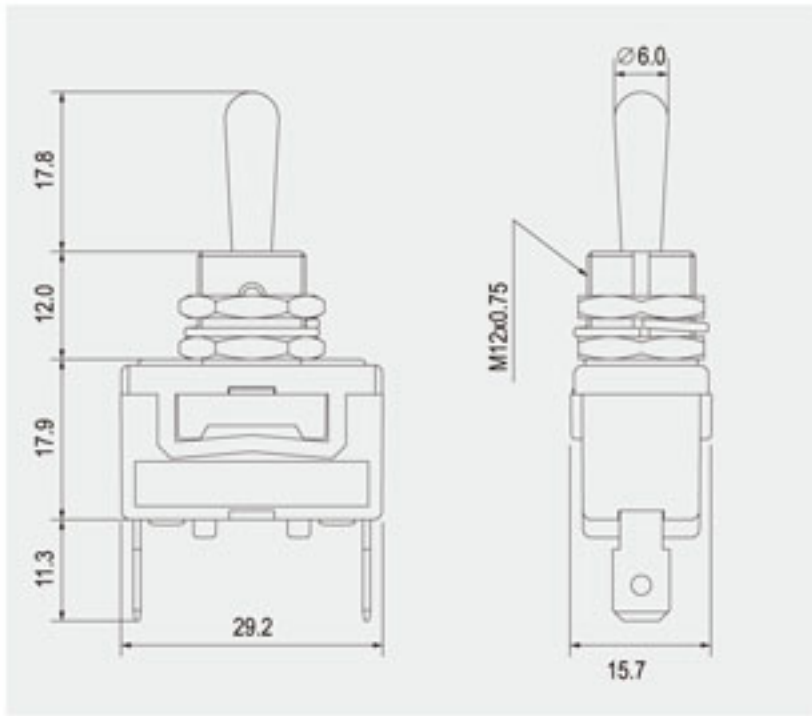

Rating
15A 125V AC 1/8HP 10A 250V AC 1/3HP
Contact resistance
50mΩ Max
Insulation resistance
DC 500V 100MΩ Min
Dielectric strength
AC 1500V 1 minute
Cut-out
6 mm max

FEATURES

- * MATERIAL: Metal lever and bushing are nickel plated metal. Frame is metal plated steel. Base is phenolic.
- * Standard toggle lever.
- * Indicator plate and waterproof boot are optional.



R13-29 -

FUNCTION

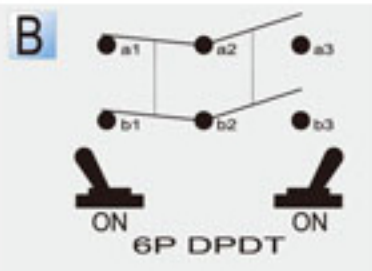

TERMINAL

0 1 .250" SQ